

Being able to provide a jet purge adapter to a piston type sampling valve, ensures optimal retrieval of a representative, contamination free sample of high viscosity liquids. The DPJ type sampler allows purging of the sample valve outlet thus eliminating dead volume. In solvent purge configuration, the system allows for purging with a solvent or with nitrogen.

**1 OPERATION/FUNCTION**

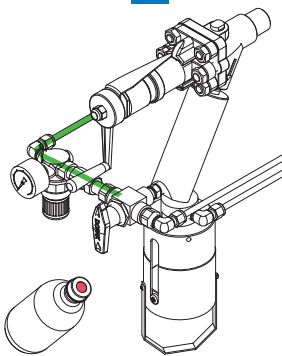

**0 - off**  
Provide a new septum on your sample bottle. Insert the bottle, with cap and septum into the sleeve until the needles pierce the septum. Put the bottle retaining clip in place.

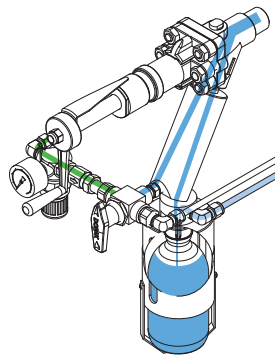

**1 - sample**  
Open the piston valve allowing the product to flow into the sample bottle. When the required amount has been taken, close the valve.

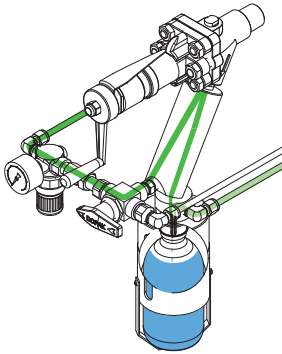

**2 - nitrogen purge**  
Turn the valve in the purge line to nitrogen, allowing a flow of purge gas through the sampler to ensure any residual liquid is forced into the sample bottle. This position can be held for any required time.

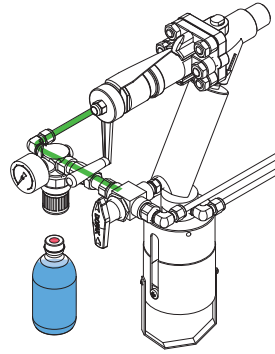

**3 - off**  
Close the valve in the purge line, remove the bottle retaining clip and pull the bottle out from the sleeve. The septum reseals automatically.

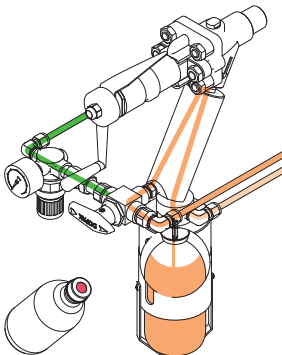

**4 - solvent purge**  
Put a new bottle in place. Turn the valve in the purge line to solvent, allowing a flow of solvent through the sampler into the sample bottle.

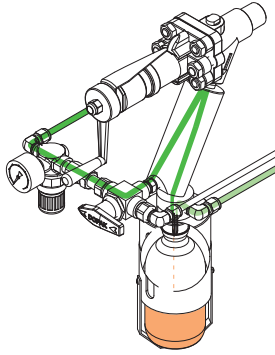

**5 - nitrogen needle purge**  
Turn the valve in the purge line to nitrogen, allowing a flow of purge gas through the sampler to ensure any residual solvent is forced into the sample bottle. This position can be held for any required time.

**2 TYPICAL P & ID**

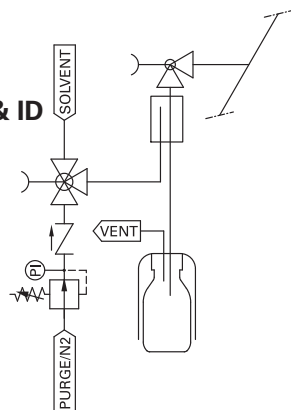

Solvent purge (C4)

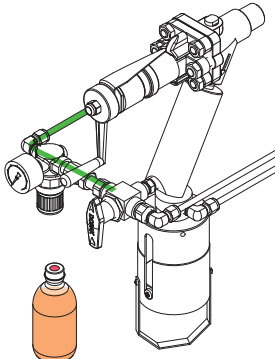

**6 - off**  
Close the valve in the purge line. Remove the bottle retaining clip and pull the bottle out from the sleeve. The septum reseals automatically.



### 3 FEATURES/ADVANTAGES/PROPERTIES

- Sampling directly under process conditions
- Low pressure applications
- Representative sampling
- Zero dead volume
- Closed sampling
- High viscosity sampling
- Purging of sampler with gas and solvent
- Retrofittable to valve

### 4 BASIC SPECIFICATIONS

<b>Material</b>	SS316, SS316L.
<b>Sleeve type</b>	60cc sleeve with bottle retaining clip.
<b>Needle assembly</b>	Single piece VTO needle assembly with vent to outlet connection 1/4" FNPT. Process/vent needle ID: 1.35 mm.
<b>Valve</b>	Piston valve. PTFE seats. Pressure range ANSI B16.34. Temperature range -29/+232°C (-20/+450°F).
<b>Operation</b>	Manual.
<b>Connections</b>	Process: 3/4" MNPT Vent: 1/4" FNPT Purge: 1/4" FNPT, needle valve, regulator, gauge and check valve included.
<b>Please note:</b>	the above is a basic specification only. DOPAK® Samplers can be offered with a wide variety of options as mentioned below.

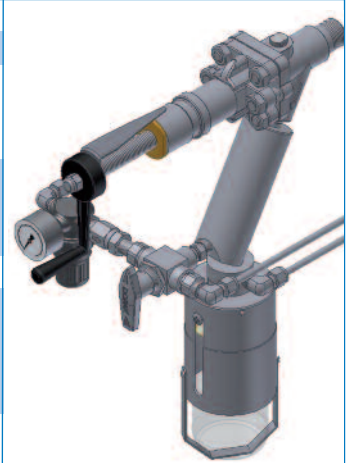

### 5 OPTIONS

- Fixed volume chamber
- Heating/cooling jacket
- Mounting plate
- Pipe stand
- Block valve
- Flow meter
- Enclosure
- Steam sterilising cap
- Mounting bracket
- Exotic materials
- Larger/smaller sample size

For more information please refer to our sheets:

**Options for DOPAK® process samplers, sampling into a bottle.**

**Components for DOPAK® process samplers.**

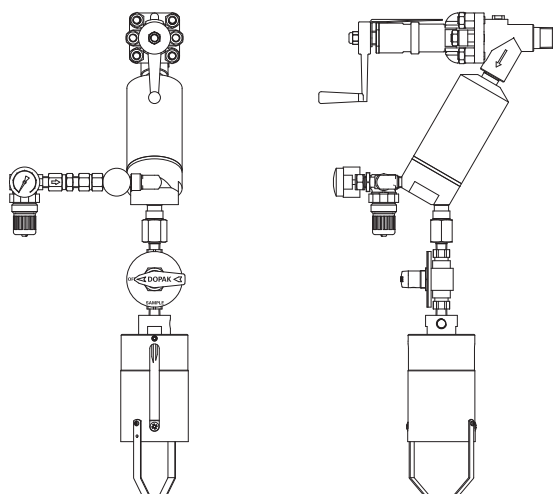

#### Dopak PFT Corp.

Houston, Texas 77041, USA

Phone 713-460-8311

Fax 713-460-8578

E-mail info-dopak@cranecpe.com

#### Dovianus BV

Bergschenhoek, The Netherlands

Phone +31 10 524 20 00

Fax +31 10 524 20 29

E-mail info-dovianus@cranecpe.com

Your local distributor