

DOPAK® Process Sampler Type DPT
in line, on/off configuration (H1)

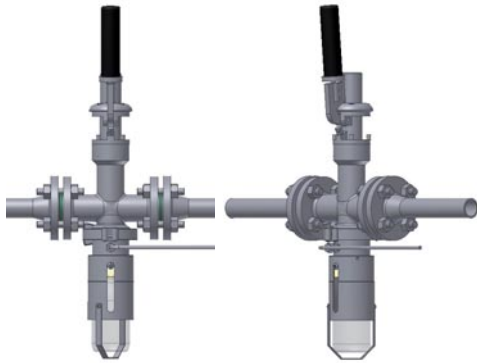

The ability to install the sampler directly in the process line ensures optimal retrieval of a representative, contamination free sample. The DPT type of sampler in on/off configuration allows the product to flow directly into the sampler via an in line sample valve.

1 OPERATION/FUNCTION

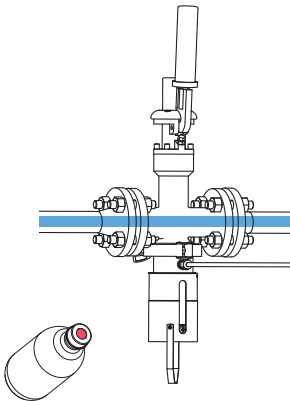

0 - off
Provide a new septum on your sample bottle. Insert the bottle, with cap and septum into the sleeve until the septum is pierced by the needles. Put the bottle retaining clip in place.

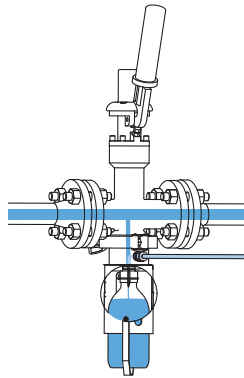

1 - sample
Pull the handle to the "sample" position, allowing the product to flow into the sample bottle. When the required amount has been taken, release the handle. The valve will close automatically.

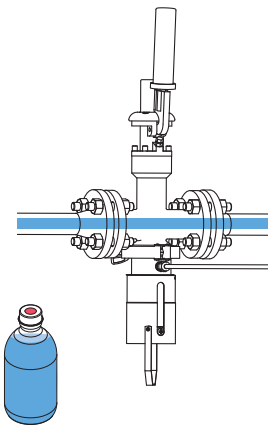

2 - off
Remove the bottle retaining clip and pull the bottle out from the sleeve. The septum reseals automatically.

2 TYPICAL P & ID

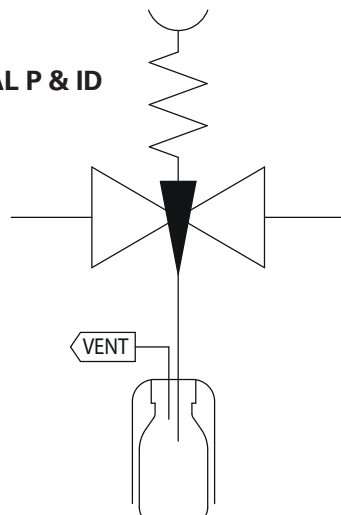

3 FEATURES/ADVANTAGES/PROPERTIES

- Sampling directly under process conditions
- Low pressure application
- Representative sampling
- Zero dead volume
- Closed sampling

4 BASIC SPECIFICATIONS

Material	SS316, SS316L.	
Sleeve type	60cc sleeve with bottle retaining clip.	
Needle assembly	Single piece VTO needle assembly with vent to outlet connection 1/4" FNPT. Process/vent needle ID: 1.35 mm.	
Valve	Inline valve. PTFE seats Viton A O-ring. Pressure range 16 bar @ 20°C (232 psig @ 70°F). Temperature range -40/+200°C (-40/+392°F).	
Operation	Spring return.	
Connections	1" - 150lbs RF ANSI B 16.5 flanges.	
Please note:	the above is a basic specification only. DOPAK® Samplers can be offered with a wide variety of options as mentioned below.	

5 OPTIONS

- Lockable handle
- Enclosure
- Steam sterilising cap
- Welded connection
- Bottle or needle purge
- Wafer style valve
- Exotic materials
- Larger/smaller sample size
- Spindle extension
- Bellows seals
- PFA lined valve
- Steam jacket

For more information please refer to our sheets:

Options for DOPAK® process samplers, sampling into a bottle.
Components for DOPAK® process samplers.

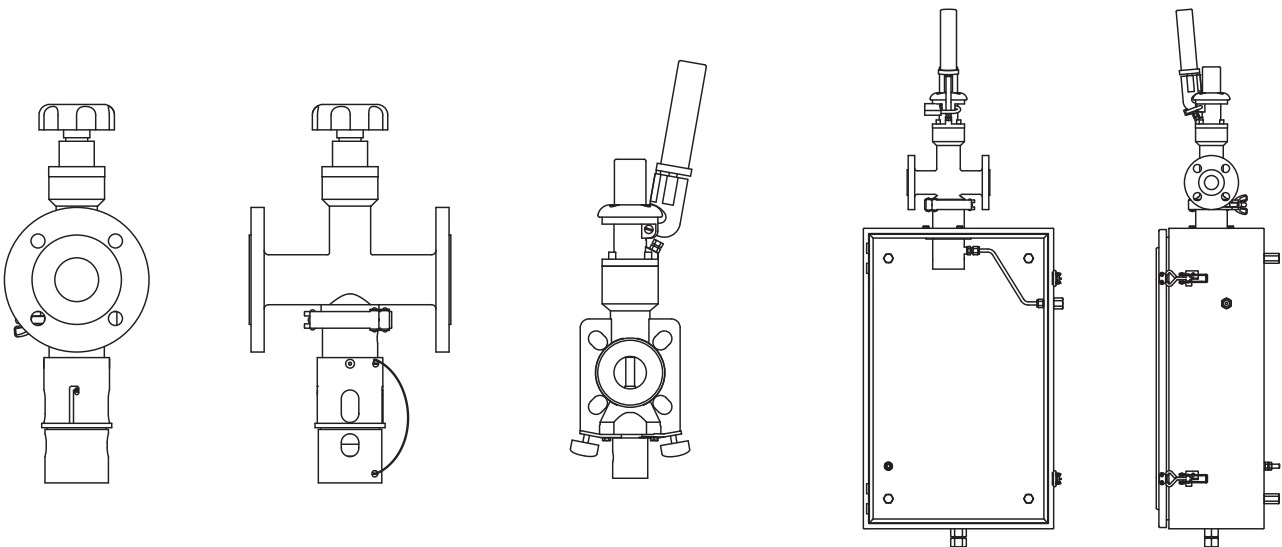

Dopak PFT Corp.

Houston, Texas 77041, USA
 Phone 713-460-8311
 Fax 713-460-8578
 E-mail info-dopak@cranecpe.com

Dovianus BV

Bergschenhoek, The Netherlands
 Phone +31 10 524 20 00
 Fax +31 10 524 20 29
 E-mail info-dovianus@cranecpe.com

Your local distributor:

