

## DOPAK® Process Sampler Type S32

### overflow vacuum configuration with venturi unit (E7)

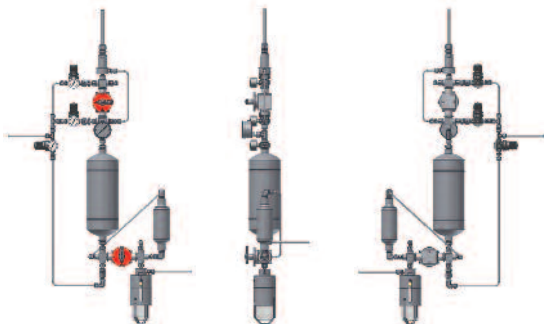

The ability to purge the sample point ensures optimal retrieval of a representative, contamination free sample. The S32 type sampler in overflow vacuum configuration provides a system purge to an overflow chamber and needle purge in addition to a fixed sample.

The unique design offers a one-handle operation by multiple valves, allowing for sampling reactors and vessels at atmospheric or vacuum conditions.

### 1 OPERATION/FUNCTION

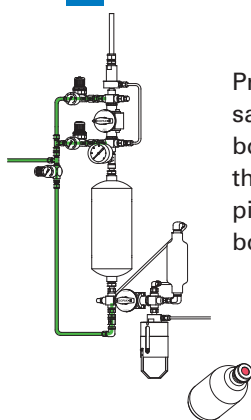

#### 0 - off

Provide a new septum on your sample bottle. Insert the sample bottle, with cap and septum into the sleeve until the septum is pierced by the needles. Put the bottle retaining clip in place.

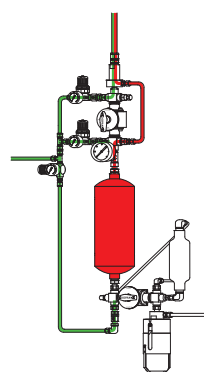

#### 1 - vacuum

Turn the handle on top of the overflow chamber to the "vacuum" position, allowing a purge of gas to flow through the venturi unit and allowing a vacuum to be created in the overflow chamber.

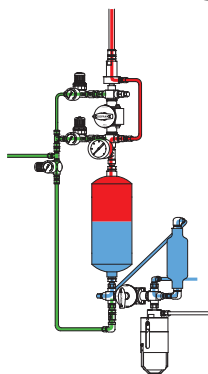

#### 2 - system purge

Turn the main handle to the "purge" position, allowing the vacuum to be connected to the process, creating a flow of liquid through the sample chamber into the overflow chamber to ensure representative sampling.

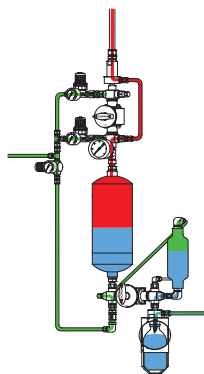

#### 3 - sample

Turn the main handle to the "sample" position allowing the product to flow into the sample bottle. The fixed volume chamber determines the amount of sample. The inert gas will assist the sample to flow into the bottle and will purge the sampler. This position can be held for any required time.

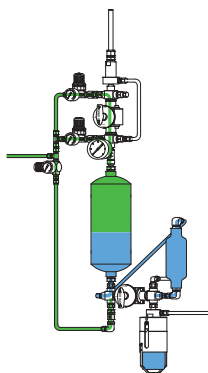

#### 4 - back purge

Turn the main handle and the handle on top of the overflow chamber both to the "purge" position, allowing an inert gas to back purge the residue material to the process connection. This position can be held for any required time.

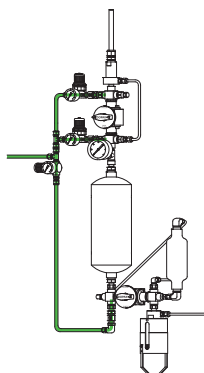

#### 5 - off

Turn all handles to the "off" position. Remove the bottle retaining clip and pull the bottle out from the sleeve. The septum reseals automatically. Put a new bottle in place.



## 2 TYPICAL P & ID

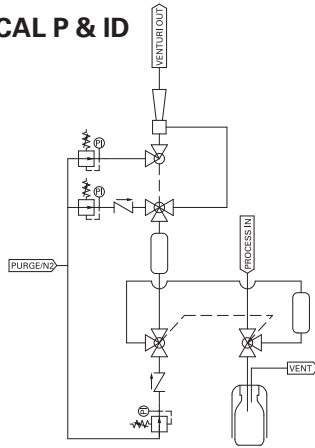

Fixed volume (venturi) (E7)

## 3 FEATURES/ADVANTAGES/PROPERTIES

- Atmospheric and vacuum applications
- Representative sampling
- Zero dead volume
- Closed sampling
- One handle operation
- Fixed volume sampling
- Purging of sampler

## 4 BASIC SPECIFICATIONS

<b>Material</b>	SS316, SS316L.
<b>Sleeve Type</b>	60cc sleeve with bottle retaining clip.
<b>Needle Assembly</b>	Single piece VTO needle assembly with vent to outlet connection 1/4" FNPT. Process/vent needle ID: 1.35 mm.
<b>Sample Chamber</b>	50cc
<b>Valve</b>	Two and three-way ball valves type W83. PTFE seats, Viton A O-rings. Pressure range 103 bar @ 20°C (1500 psig @ 70°F). Temperature range -17/+232°C (0/+450°F).
<b>Operation</b>	Manual.
<b>Connections</b>	1/4" FNPT. Regulator, gauge and check valve included.
<b>Venturi out</b>	1/2" FNPT.
<b>Please note:</b>	the above is a basic specification only. DOPAK® Samplers can be offered with a wide variety of options as mentioned below.

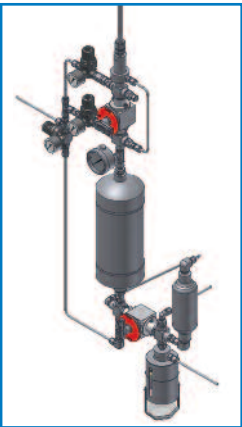

## 5 OPTIONS

- Spring return handle
- Lockable handle
- Mounting plate
- Pipe stand
- Block valve
- Flow meter
- Enclosure
- Sample cooler
- Mounting bracket
- Continuous needle purge
- Exotic materials
- Larger/smaller sample size

For more information please refer to our sheets:

**Options for DOPAK® process sampler, sampling into a bottle.**

**Components for DOPAK® process samplers.**

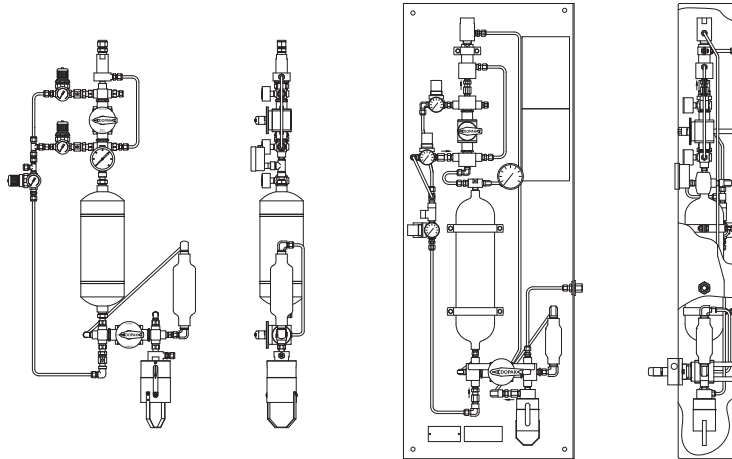

W R S N I a p + V R S D

c R V R D + p H H @ D A 7 +

I K R + H A C 8 D F @ 8 I C A A

a R f H A C 8 D F @ 8 I E H I

Z 8 R L Q L O R B G S N S R U G S 9 F P

W R L O X U r

U R U R G E N + p K I H R U D O X

I K R + 6 C A @ + E B D @ B @ +

a R f 6 C A + A @ + E B D + B @ + B K

Z 8 R L Q L O R B G R O X S R U G S 9 F P

Your local representative: